



SEAL KIT INSTRUCTION SHEET

SUBJECT:

SEAL AND BEARING REPLACEMENT IN CENTRAL DIAPHRAGM (OLD AND NEW STYLE) 5.3/4" AIR DRIVES. DOUBLE AND TRIPLE AIR HEAD MODELS

DESCRIPTION:

These center diaphragms are used on the double and triple air head drives for liquid pumps and gas boosters.

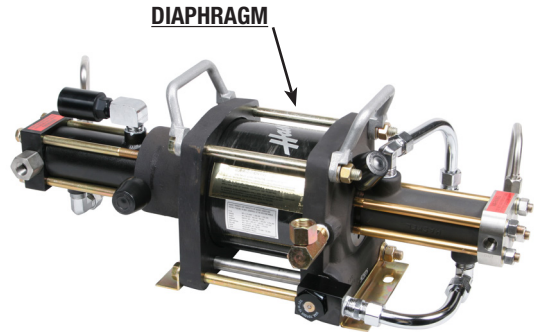
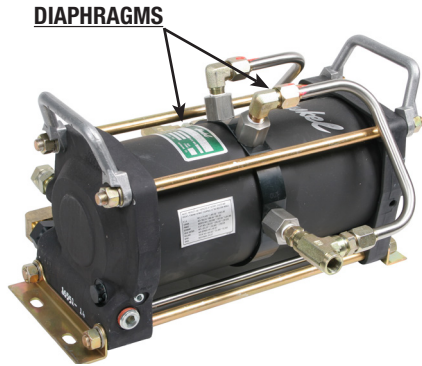

DESIGN IMPROVEMENTS:

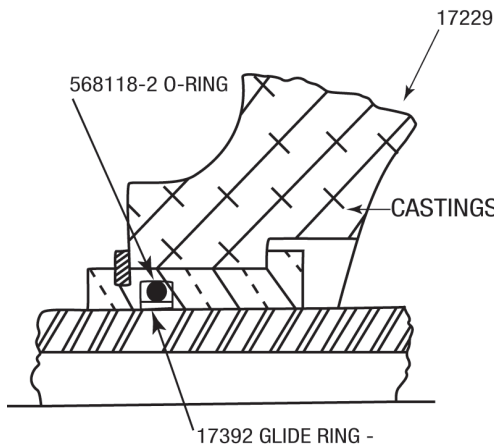

OLD STYLE
ALL PUMPS AND GAS BOOSTERS

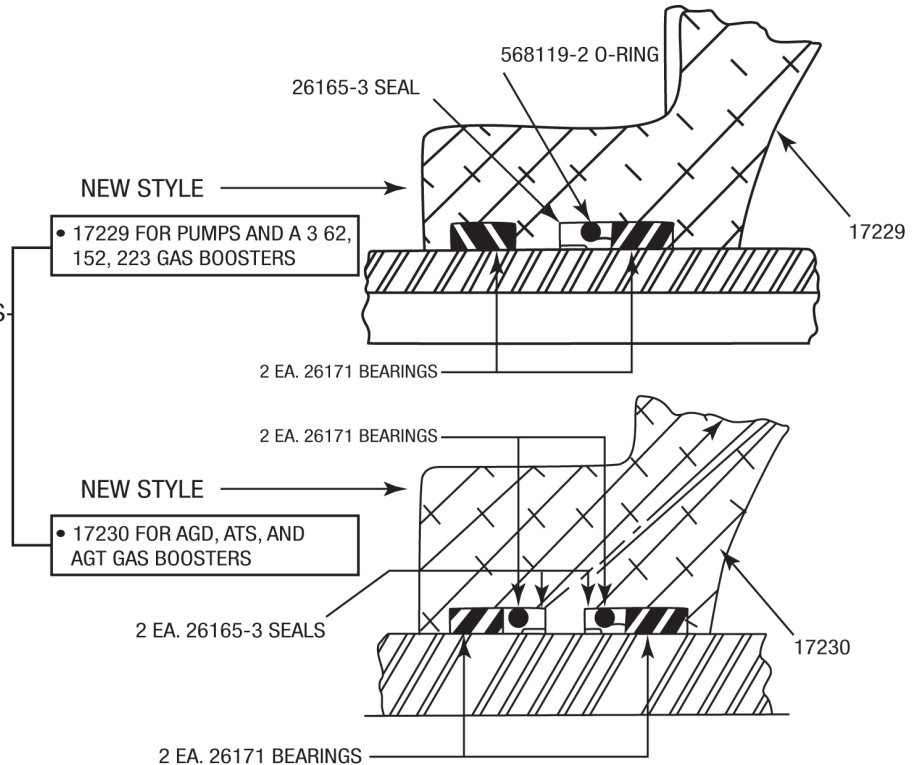

NOTE: INSTALL 568119-2 O-RING AROUND 26165-3 SEAL AND FOLD BOTH INTO AN OVAL SHAPE TO INSERT INTO GROOVE IN CASTING.

REFERENCES:

16773	28513	29255
17326	28611	29412
17705	28612	55438