

10A4500 / 10A4600 VA Master™ Indicating Flowrator®

The measurement solution for visual flow indication

Measurement made easy



Rugged, high-strength stainless steel body

- Suited with corrosion-resistant type 300 stainless steel support frame
- Slim design for space limited installation locations

Flexibility with ease

- Easily removable tube and float for re-ranging or maintenance purposes without removing from line
- Available with snap-in O-ring option or packing gland assembly
- Versatile, universal threaded or flanged rotating and field adjustable end fittings for any connection orientation

Safety and operator protection

- Safe operation with thick-walled polycarbonate shield designed to protect personnel from glass fragments in the event of accidental tube rupture
- Rear- and downward-facing slots to divert flows in the event of rupture

Maximized visibility

- Wide-angle view local visual indication with polished protector shield

Versatile indicating and alarm options

- Suited with up to three scales for varying process conditions
- Optional alarm system for minimum and/or maximum limits.

High corrosion-resistant model

- Optional configuration with wetted components suited for aggressive liquids

10A4500 / 10A4600 VA Master™ Indicating Flowrator®

VA Master™ Indicating Flowrator®

The ABB VA Master Flowrator meter is a glass tube variable area flowmeter that provides visual indication of flow rate over a 12^{-1/2} to 1 range on a linear scale. It can be fitted with an O-ring or packing gland seal design for application suitability.

With either seal design, the glass meter tube is easily removable for re-ranging or cleaning and without the need to disassemble fittings or remove from the meter from the line. Both types have the same installation dimensions and are interchangeable with regard to piping assembly. An optional alarm system with one or two bi-stable sensors can be integrated for open/close signals for rising or falling flowrates.

Universal threaded process connections allow for horizontal or vertical in-line installation and can be fitted with screw-on flanges as a standard option

Principle of operation

The function of a variable area flowmeter, commonly known as a Rotameter, depends on the dynamic equilibrium of a free floating body being acted on by various physical forces within a closed system. The free body is referred to as a float and the closed system as a tube with controlled geometric characteristics, namely its variable cross-sectional area. The float is free to move vertically up and down the symmetrical tube and is acted on by the various forces. The main three are gravity, buoyancy and inertial forces. The float weight represents the magnitude of gravity. The float will remain at the bottom of the tube until buoyancy and inertial forces of a fluid flow act in the opposite, upward direction against gravity.

The float is designed to have a diameter large enough to restrict passage of fluid and a higher density than the measured fluid. As a liquid or gas begins to flow through the tube, the buoyancy lightens the float but is not sufficient to allow it to truly 'float'. The inertial force of flow passage of a fluid around the float creates resistance and the fluid pressure drop starts increasing. When the upward buoyancy and inertial forces exceed the force of gravity, the float begins to move up the tube until the open cross sectional area is large enough to reduce the differential pressure until the float reaches an equilibrium position a distance up the tube which is then related to a specific flowrate marked on a scale.

Aside from the governing equations and consideration of all acting forces, the variable area flowmeter is also influenced by several fouling factors like fitting or valve discharge coefficients or other obstructions. These are accounted for with the use of prediction flow curves fine-tuned with the use of decades of calibration and test data. The scales used to relate a float position up the tube to a flowrate are dependent on this empirical data and the equilibrium governing equations which take into account the flowing process conditions such as density, temperature and static pressure.

Operational components

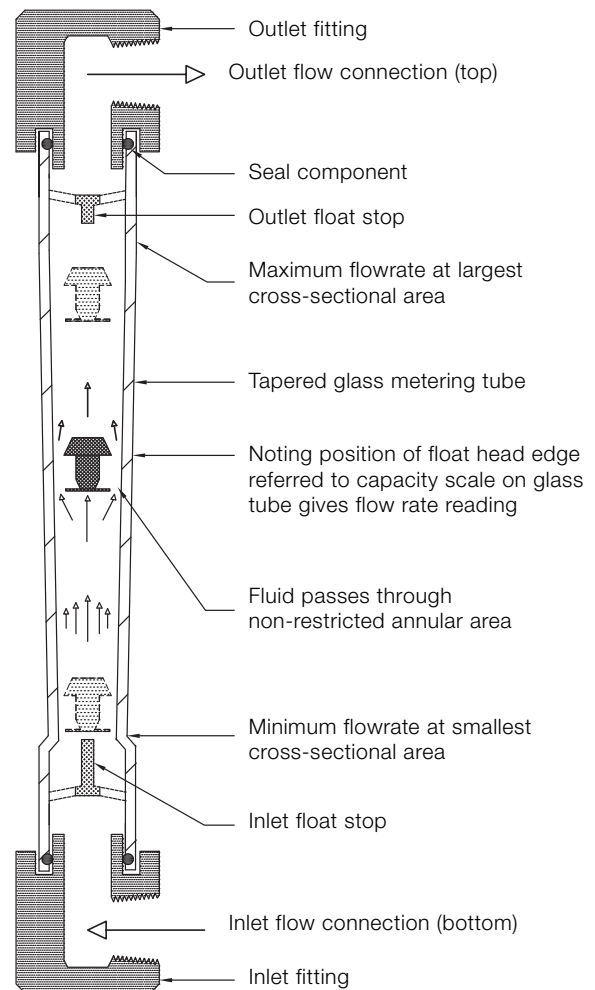

Fig. 1: Basic components of a variable area meter. Support fittings, tube and float

Specification – model 10A4500

Measurement

Fluid

Gases, clean liquids

Flow range

12¹/₂ to 1

Repeatability

0.5 % full scale

Accuracy

2 % full scale

1 % optional with calibration

Connections

Sizes

1/2, 3/4, 1, 1 1/2

Types

Threaded F-NPT, flanged

Orientations

Vertical:

Top, bottom

Horizontal:

Left, right, back

Scales

Sizes

Standard 10 in. (9 in. for 1/2 to 50 only)

Types

Direct, percent (on metal scale), tube, both

Materials of construction

Tube

Borosilicate glass

Tube rest gaskets

Klinger-Sil

Tube retainer spring

Armco 17-7 pH stainless steel

Fittings

316 stainless steel, others available

Meter body

304L stainless steel

Seals (by type)

Packing gland:

Neoprene, PTFE

O-rings:

Buna-N, Viton®, EPR

Float

316 stainless steel

Non-standard (extended lead time):

Hastelloy-C, Monel, Tantalum, PVC (lead loaded), PTFE

Float stops

PTFE

Alarms

Types

High, low, high/low, high/high, low/low, DPDT, SPDT

Electrical specifications

Power requirements

120V AC (standard)

220V AC / 24V DC available on request

Contact rating

Max. 250 V; Max. 2A

Sensor switch cable length

Standard – 6.5 ft.

Optional – up to 980 ft.

Sensor safety classification

Intrinsically safe – Class I, Div. 1, Group A-D & Class II, Div. 1 Group E-G with amplifier in non-hazardous location

General

Mounting

Line, front panel, rear panel (not available with flanges)

Float and tube combinations

See capacity tables below

Valves

Optional external needle valve (316 stainless steel and nipple un-assembled)

Services

Oxygen cleaning, standard calibration, high viscosity calibration (up to 100 cst), hydro testing

10A4500 / 10A4600

VA Master™ Indicating Flowrator®

Specification – model 10A4600

Measurement

Fluid

Gases, clean liquids

Flow range

12¹/₂ to 1

Repeatability

0.5 % full scale

Accuracy

2 % full scale

1 % optional with calibration

Connections

Sizes

¹/₂, ³/₄, 1, 1¹/₂

Types

Threaded F-NPT, flanged

Orientations

Vertical

Scales

Sizes

Standard 10 in. (9 in. for ¹/₂ to 50 only)

Types

Direct, percent (on metal scale), tube, both

Materials of construction

Tube

Borosilicate glass

Tube rest gaskets

PTFE

Tube retainer spring

Armco 17-7 pH stainless steel

Fittings

PVC

Meter body

304L stainless steel

Seals (by type)

Packing gland:

PTFE

O-rings:

N/A

Float

316 stainless steel

Non-standard (extended lead time):

Hastelloy-C, Monel, Tantalum, PVC (lead loaded), PTFE

Float stops

PTFE

Alarms

Types

High, low, high/low, high/high, low/low, DPDT, SPDT

Electrical specifications

Power requirements

120V AC (standard)

220V AC / 24V DC available on request

Contact rating

Max. 250 V; Max. 2A

Sensor switch cable length

Standard – 6.5 ft.

Optional – up to 980 ft.

Sensor safety classification

Intrinsically safe – Class I, Div.1, Group A-D & Class II,

Div.1 Group E-G with amplifier in non-hazardous location

General

Mounting

Line, front panel, rear panel (not available with flanges)

Float and tube combinations

See capacity tables below

Valves

Optional external needle valve (316 stainless steel and nipple un-assembled)

Services

Oxygen cleaning, standard calibration, high viscosity calibration (up to 100 cst), hydro testing

Specification – service conditions (all models)

Pressure rating – stainless steel fittings

Connection size (in.)	Tube size (in.)	Maximum design pressure PSIG (kPa) @ 100 °F (38 °C)	
		NPT	Flange
1/2		300 (2070)	275 (1890)
3/4	3/4 and 1	200 (1380)	–
1	3/4 and 1	200 (1380)	200 (1380)
1 1/2		130 (890)	130 (890)
1 1/2	2	100 (690)	100 (690)

Pressure rating – PVC fittings

Connection size (in.)	Tube size (in.)	Maximum design pressure			
		NPT		Flange	
		100 °F (38 °C)	140 °F (60 °C)	100 °F (38 °C)	140 °F (60 °C)
1/2		260 (1790)	92 (634)	150 (1035)	50 (345)
3/4	3/4 and 1	200 (1380)	75 (517)	–	–
1	3/4 and 1	–	–	150 (1035)	50 (345)
1 1/2		130 (897)	53 (365)	130 (897)	50 (345)
1 1/2	2	100 (690)	53 (365)	100 (690)	50 (345)



- Ensure that installation location process conditions will not exceed the allowable operating conditions.
- Applications: Glass tube meters are not recommended for continuous service on alkalis above 100 °F (38 °C) or more than 20 % concentrations; nor for fluorine, hydrofluoric acid, water above 200 °F (93 °C), steam, slurries, or molten metal.
- Is it important that the O-ring material be compatible with the process fluid. Meter tube breakage can occur if the wrong material is used. For example: VITON O-RING MUST NEVER BE USED FOR AMMONIA SERVICE.

Temperature rating

Minimum recommended process fluid temperature is 32 °F (0 °C). Maximum recommended process fluid temperature is 250 °F (121 °C).

Ambient temperature range

32 to 140 °F

Weights

Connection size (in.)	Tube size (in.)	Stainless steel fittings		PVC fittings	
		Threaded	Flanged	Threaded	Flanged
		Weight in lbs. (kg)			
1/2		8.5 (3.9)	12 (5.5)	8 (3.6)	50 (345)
3/4	3/4 and 1	17 (7.5)	–	15 (6.8)	–
1	3/4 and 1	–	21 (9.5)	–	18 (9.2)
1 1/2	1 1/2 and 2	29 (13)	35 (16)	25 (11.3)	30 (13.6)

10A4500 / 10A4600

VA Master™ Indicating Flowrator®

Accessories

Metal scale plate(s)	Graduated metal scale plate mounted adjacent to metering tube.
Alarms	One or two* bi-stable alarm switches, adjustable over entire scale length to give contact closure (or opening) upon rising or falling flow. Available with SPDT or DPDT switch action. *Note when using two switches, the minimum spacing is on 1 in. centers (approx. 10 % of full scale).
Surface (front) panel mounting	Nuts, bolts, and lock washers for mounting meter against front of panel by means of mounting holes provided in every meter body.
Flush (rear) panel mounting	Brackets, bezel and hardware for mounting meter behind panel.
Welded Flanges	Upon request, flanges / nipples / end fittings can be supplied as a welded assembly.



WARNING – Glass tube Rotameters must not be operated without the operator protection shield in place. Doing so could result in serious injury to personnel.

Corrosion resistant material options

The V/A Master is available with various corrosion resistant material options and takes advantage of the inherent chemical resistivity of borosilicate glass tubes. PVC fittings are available as a standard option with PTFE or Neoprene packing glands. Additionally, several float designs are available out of PTFE, PVC and Tantalum for liquid applications.

Ordering information

To eliminate any delays in the processing of orders and to ensure prompt delivery, please specify:

- Complete model number
- Accuracy desired
- Alarm settings if applicable
- Operating conditions
- Fluid measured
- Maximum flow rate and unit of flow
- Fluid density
- Fluid viscosity
- Allowable pressure drop
- Operating and maximum temperature
- Operating and maximum pressure

Meter sizing

Simplified sizing is possible with the use of capacity tables. These are a set of tabulated values for each tube and float combinations. The values displayed are of water or air with densities at standard temperature and pressure (STP). The values on these tables can be used directly if the process fluid is air or liquid under STP process conditions.

If process conditions are other than STP, the following equations can be used to find a 'water or air equivalent' value. QA or QW values can be found by specifying operating conditions. These values can then be used to select the most adequate tube and float combination. Special attention must be taken when converting process conditions to specified variable units. Equations 1-4 are used for stainless steel floats, and equations 5-6 for floats of other materials.

Capacity tables liquid conversion equations (stainless steel floats only)

Volumetric water equivalent (equation 1)

$$Q_W = Q_L \times \sqrt{\frac{7.02 \times P_f}{8.02 - P_f}}$$

Gravimetric (mass) water equivalent (equation 2)

$$Q_W = \frac{W_L}{8.33 \times P_f} \times \sqrt{\frac{7.02 \times P_f}{8.02 - P_f}}$$

Where:

- Q_W = water equivalent in gpm
- Q_L = process fluid flowrate in gpm
- W_L = process fluid mass flowrate in lb/min
- P_f = process fluid density in S.G. with respect to water density at 70 °F

Capacity tables gas conversion equations (stainless steel floats only)

Volumetric air equivalent (equation 3)

$$Q_A = Q_G \times \sqrt{\frac{14.7 \times P_g \times T_o}{530 \times P_o}}$$

Gravimetric (mass) air equivalent (equation 4)

$$Q_A = 13.34 \times W_g \times \sqrt{\frac{14.7 \times T_o}{530 \times P_g \times P_o}}$$

Where:

- Q_A = air equivalent in SCFM
- Q_G = process fluid flowrate in SCFM
- W_g = process fluid mass flowrate in lb/min
- P_g = process fluid density in S.G. with respect to air density at 70 °F and 14.7 psia
- T_o = operating temperature in °R
- P_o = operating pressure in psia

Capacity tables liquid conversion equations (non-stainless steel floats) – refer to capacity tables 4 and 5

Volumetric water equivalent (equation 5)

$$Q_W = Q_L \times \sqrt{\frac{(P_c - 1) \times P_f}{P_c - P_f}}$$

Gravimetric (mass) water equivalent (equation 6)

$$Q_W = \frac{W_L}{8.33 \times P_f} \times \sqrt{\frac{(P_c - 1) \times P_f}{P_c - P_f}}$$

Where:

- Q_W = water equivalent in gpm
- Q_L = process fluid flowrate in gpm
- W_L = process fluid mass flowrate in lb/min
- P_c = float density in g/cm³ *
- P_f = process fluid density in S.G. with respect to water density at 70 °F

* Float densities in g/cm³

Tantalum: 16.6

PTFE: 2.31

PVC: 5.5

10A4500 / 10A4600

VA Master™ Indicating Flowrator®

Capacity tables

Tube size (in.)	Maximum flow		Tube number	Float number (316 stainless steel)	Float code	Tube code	Total DP (Note 1)	VIC (Note 2)	psia critical (Note 3)
	Water equivalent (gpm) – Q _w	Air equivalent (SCFM) – Q _A							
1/2	0.198	0.8	FP-1/2-17-G-10	1/2-GUSVT-410	01	A1	0.53	2.2	3.6
	0.238	0.982	FP-1/2-21-G-10	1/2-GUSVT-410	01	A2	0.53	2.2	3.6
	0.324	1.339	FP-1/2-27-G-10	1/2-GUSVT-410	01	A3	0.58	2.2	3.6
	0.436	1.796	FP-1/2-35-G-10	1/2-GUSVT-410	01	A4	1	2.2	3.6
	0.825	3.4	FP-1/2-50-G-9	1/2-GUSVT-410	01	A6	2	2.2	3.6
3/4	0.633	2.62	FP-3/4-21-G-10	3/4-GUVT-510	02	B1	0.6	3.3	3.1
	0.86	3.54	FP-3/4-27-G-10	3/4-GUVT-510	02	B2	0.71	3.3	1.5
1	1.205	4.98	FP-1-27-G-10	1-GUSVT-611	03	C1	1.28	4	1
	1.67	6.9	FP-1-35-G-10	1-GUSVT-611	03	C2	1.83	4	0.75
	2.58	10.7	FP-1-27-G-10	1-GUSVT-610	04	C1	5.47	8.6	4.5
	3.6	14.84	FP-1-35-G-10	1-GUSVT-610	04	C2	7.97	8.6	3.4
1 1/2	2.45	10.3	FP-1 1/2-21-G-10	1 1/2-GUSVT-867	05	D1	0.92	6.5	1
	3.33	13.8	FP-1 1/2-27-G-10	1 1/2-GUSVT-867	05	D2	1.24	6.5	1
	6.5	27	FP-1 1/2-21-G-10	1 1/2-GUSVGT-814	06	D1	5.75	16.2	6.8
	8.7	36	FP-1 1/2-27-G-10	1 1/2-GUSVGT-814	06	D2	7.2	16.2	6.8
2	5.54	22.9	FP-2-27-G-10	2-GUSVT-913	07	E1	1.65	8.9	1
	13.75	56.7	FP-2-27-G-10	2-GUSVT-914	08	E1	9	22	6.2

Table 1: Low pressure drop design

Notes

1. Pressure drop is total pressure loss across the meter at 100 % flow rate in inches of water column.
2. Meter is unaffected by viscosity when the value of cps/\sqrt{p} (using p = operating density in g/cc and cps = viscosity in centipoise) is less than VIC (viscosity immunity ceiling). VIC is applicable to liquids only – all gas flows fall below VIC.
3. Meters are not recommended for gas service where pressure is below minimum shown. A flow throttling valve close-coupled to meter outlet is not recommended for all gas applications.
4. Standard percent scales are not applicable to low pressure drop floats.
5. Values for Q_w and Q_A (water and air flow equivalents) can be determined using equations 1-4. See 'Meter sizing' on page 7.

Tube size (in.)	Maximum flow		Tube number	Float number (316 stainless steel)	Float code	Tube code	Total DP (Note 1)	VIC (Note 2)	psia critical (Note 3)
	Water equivalent (gpm) – Q _w	Air equivalent (SCFM) – Q _A							
1/2	0.267	1.1	FP-1/2-17-G-10	1/2-GUSVT-40A	09	A1	1.2	2.9	5.5
	0.328	1.35	FP-1/2-21-G-10	1/2-GUSVT-40A	09	A2	1.4	2.9	3.5
	0.442	1.82	FP-1/2-27-G-10	1/2-GUSVT-40A	09	A3	2	2.9	2.7
	0.48	1.92	FP-1/2-17-G-10	1/2-GSVT-45A	10	A1	3.5	5.1	17.9
	0.6	2.47	FP-1/2-21-G-10	1/2-GSVT-45A	10	A2	4.6	5.1	11.5
	0.619	2.55	FP-1/2-35-G-10	1/2-GUSVT-40A	9	A4	3.1	2.9	2
	0.67	2.76	FP-1/2-17-G-10	1/2-GSVT-44A	11	A1	6.4	7.1	33.4
	0.69	2.85	FP-1/2-17-G-10	1/2-GSVT-48A	12	A1	7.3	7.6	39
	0.81	3.35	FP-1/2-27-G-10	1/2-GSVT-45A	10	A3	6.8	5.1	8.4
	0.83	3.42	FP-1/2-21-G-10	1/2-GSVT-44A	11	A2	7.7	7.1	33.8
	0.88	3.62	FP-1/2-21-G-10	1/2-GSVT-48A	12	A2	8	7.6	24.6
	0.885	3.65	FP-1/2-17-G-10	1/2-GNSVT-48A	13	A1	8.2	1.1	19.8
	1.1	4.52	FP-1/2-21-G-10	1/2-GNSVT-48A	13	A2	9.9	1.1	20
	1.12	4.6	FP-1/2-27-G-10	1/2-GSVT-44A	11	A3	12.3	7.1	16.2
	1.15	4.74	FP-1/2-35-G-10	1/2-GSVT-45A	10	A4	8.2	5.1	8.5
	1.19	4.9	FP-1/2-27-G-10	1/2-GSVT-48A	12	A3	13.7	7.6	18.6
	1.44	5.93	FP-1/2-27-G-10	1/2-GNSVT-48A	13	A3	15.8	1.1	16.5
	1.56	6.43	FP-1/2-35-G-10	1/2-GSVT-44A	11	A4	14.8	7.1	16.5
	1.66	6.85	FP-1/2-35-G-10	1/2-GSVT-48A	12	A4	17.2	7.6	18.8
	3/4	2	8.24	FP-1/2-50-G-9	1/2-GSVT-45A	10	A6	12	5.1
2.76		11.4	FP-1/2-50-G-9	1/2-GSVT-44A	11	A6	31	7.1	7.7
2.9		12	FP-1/2-50-G-9	1/2-GSVT-48A	12	A6	35.2	7.6	8.9
3.52		14.5	FP-1/2-50-G-9	1/2-GNSVT-48A	13	A6	52	1.1	8.8
1.96		8.1	FP-3/4-21-G-10	3/4-GSVGT-54A	14	B1	5.3	10.4	13.9
2.49		10.2	FP-3/4-21-G-10	3/4-GNSVGT-54A	15	B1	6.8	1.6	13.9
2.66		11	FP-3/4-21-G-10	3/4-GSVGT-59A	16	B1	7	14.1	28.7
2.7		11.1	FP-3/4-27-G-10	3/4-GSVGT-54A	14	B2	7.7	10.4	9.6
3.37		13.9	FP-3/4-21-G-10	3/4-GNSVGT-59A	17	B1	11.5	2.1	25.3
3.55		14.6	FP-3/4-27-G-10	3/4-GNSVGT-54A	15	B2	11.5	1.6	9.6
1	3.67	15.1	FP-3/4-27-G-10	3/4-GSVGT-59A	16	B2	13.7	14	19.8
	4.8	19.8	FP-3/4-27-G-10	3/4-GNSVGT-59A	17	B2	20.5	2.1	19.8
	4.25	17.5	FP-1-27-G-10	1-GSVGT-64A	18	C1	12.9	14.8	11.5
	4.82	19.9	FP-1-27-G-10	1-GSVGT-68A	19	C1	18.7	16.9	15.6
	5.63	23.2	FP-1-27-G-10	1-GNSVGT-64A	20	C1	20.7	2.2	11.3
	6	24.7	FP-1-35-G-10	1-GSVGT-64A	18	C2	24.6	14.8	6.8
	6.46	26.6	FP-1-27-G-10	1-GNSVGT-68A	21	C1	32.5	2.5	15.6
	6.8	28	FP-1-35-G-10	1-GSVGT-68A	19	C2	37	16.9	8.9
	7.62	31.4	FP-1-27-G-10	1-GNSVGT-69A	23	C1	75	1.5	22.2
	7.84	32.4	FP-1-35-G-10	1-GNSVGT-64A	20	C2	37.7	2.2	6.8
	9	37	FP-1-35-G-10	1-GNSVGT-68A	21	C2	62.8	2.5	8.9
9.5	39.2	FP-1-35-G-10	1-GSVGT-69A	22	C2	65.3	8.5	13.4	
11	45.3	FP-1-35-G-10	1-GNSVGT-69A	23	C2	112	1.5	13.4	

Table 2: Bead guide meters with USV, SV and NSV floats

10A4500 / 10A4600

VA Master™ Indicating Flowrator®

Tube size (in.)	Maximum flow		Tube number	Float number (316 stainless steel)	Float code	Tube code	Total DP (Note 1)	VIC (Note 2)	psia critical (Note 3)
	Water equivalent (gpm) – Q _w	Air equivalent (SCFM) – Q _A							
1½	13.2	54.4	FP-1½-27-G-10	1½-GSVGT-87A	24	D2	9.5	27.6	15.4
	14.6	60	FP-1½-27-G-10	1½-GSVGT-86A	25	D2	13.5	31	22
	17.6	72	FP-1½-27-G10	1½-GNSVGT-87A	26	D2	12.8	4.2	15.4
	18.6	76.5	FP-1½-27-G10	1½-GNSVGT-86A	27	D2	15.2	4.8	22
2	24	99	FP-2-27-G-10	2-GSVGT-97A	28	E1	24	26.5	16.4
	30	123.8	FP-2-27-G-10	2-GSVGT-98A	29	E1	34	18.5	21.2
	32	132	FP-2-27-G-10	2-GNSVGT-97A	30	E1	32	3	16.4
	36.1	149	FP-2-27-G-10	2-GNSVGT-98A	31	E1	45	3.3	21.2
	48.0(5)	-	FP-2-27-G-10	BL-954	32	E1	70	2	-
	60.0(5)	-	FP-2-27-G-10	BL-953	33	E1	95	2	-
	68.0(5)	-	FP-2-27-G-10	BL-950	34	E1	110	2	-
	90(5)	-	FP-2-27-G-10	BL-951	35	E1	192.7	1	-

Table 2: Bead guide meters with USV, SV and NSV floats (continued)

Notes

1. Pressure drop is total pressure loss across the meter at 100 % flow rate in inches of water column.
2. Meter is unaffected by viscosity when the value of cps/\sqrt{p} (using p = operating density in g/cc and cps = viscosity in centipoise) is less than VIC (viscosity immunity ceiling). VIC is applicable to liquids only – all gas flows fall below VIC.
3. Meters are not recommended for gas service where pressure is below minimum shown. A flow throttling valve close-coupled to meter outlet is not recommended for all gas applications.
4. Unless other shown, range is equal to, or greater than, 12.5:1.
5. Short range floats; BL-954 is 8:1; BL-953 is 3.5:1; BL-950 & BL-951 are 3:1.
6. Values for Q_w and Q_A (water and air flow equivalents) can be determined using equations 1-4. See 'Meter sizing' on page 7.

Tube size (in.)	Maximum flow		Tube number	Float number (316 stainless steel)	Float code	Tube code	Total DP (Note 1)	VIC (Note 2)	psia critical (Note 3)
	Water equivalent (gpm) – Q _w	Air equivalent (SCFM) – Q _A							
1/2	0.67	2.76	FP-1/2-17-G-10	1/2-GSVTA-44	36	A1	6.4	7.1	33.4
	0.69	2.85	FP-1/2-17-G-10	1/2-GSVTA-48	37	A1	7.3	7.6	39
	0.83	3.42	FP-1/2-21-G-10	1/2-GSVTA-44	36	A2	7.7	7.1	33.8
	0.88	3.62	FP-1/2-21-G-10	1/2-GSVTA-48	37	A2	8	7.6	24.6
	0.885	3.65	FP-1/2-17-G-10	1/2-GNSVTA-48	38	A1	8.2	1.1	19.8
	1.03	4.24	FP-1/2-21-G-10	1/2-GNSVTA-44	39	A2	8.9	1.1	33.4
	1.1	4.52	FP-1/2-21-G-10	1/2-GNSVTA-48	38	A2	9.9	1.1	20
	1.12	4.6	FP-1/2-27-G-10	1/2-GSVTA-44	36	A3	12.3	7.1	16.2
	1.19	4.9	FP-1/2-27-G-10	1/2-GSVTA-48	37	A3	13.7	7.6	18.6
	1.44	5.93	FP-1/2-27-G-10	1/2-GNSVTA-48	38	A3	15.8	1.1	16.5
	1.56	6.43	FP-1/2-35-G-10	1/2-GSVTA-44	36	A4	14.8	7.1	16.5
	1.66	6.85	FP-1/2-35-G-10	1/2-GSVTA-48	37	A4	17.2	7.6	18.8
	1.84	7.6	FP-1/2-27-G-10	1/2-GNSVTA-43	40	A3	18.5	1.3	27.5
	2	8.24	FP-1/2-35-G-10	1/2-GNSVTA-48	38	A4	19	1.1	8.8
	2.43	10	FP-1/2-35-G-10	1/2-GNSVTA-43	40	A4	30	1.3	22.7
	2.76	11.4	FP-1/2-50-G-9	1/2-GSVTA-44	36	A6	31	7	7.7
	2.9	12	FP-1/2-50-G-9	1/2-GSVTA-48	37	A6	35.2	7.6	8.9
	3.52	14.5	FP-1/2-50-G-9	1/2-GNSVTA-48	38	A6	52	1.1	8.8
	4	16	FP-1/2-50-G-9	1/2-GNSVTA-43	40	A6	72	1.3	12.3
3/4	1.96	8.1	FP-3/4-21-G-10	3/4-GSVTA-54	41	B1	5.3	10.4	13.9
	2.49	10.2	FP-3/4-21-G-10	3/4-GNSVTA-54	42	B1	6.8	1.6	13.9
	2.7	11.1	FP-3/4-27-G-10	3/4-GSVTA-54	41	B2	7.7	10.4	9.6
	3.15	13	FP-3/4-21-G-10	3/4-GSVTA-53	43	B1	11	16.6	36
	3.55	14.6	FP-3/4-27-G-10	3/4-GNSVTA-54	42	B2	11.5	1.6	9.6
	3.85	15.8	FP-3/4-27-G-10	3/4-GSVTA-56	44	B2	12	14.9	19.8
	4.35	18	FP-3/4-27-G-10	3/4-GSVTA-53	43	B2	13	16.8	25
	5.05	20.8	FP-3/4-27-G-10	3/4-GNSVTA-56	45	B2	14	2.2	19.8
	5.7	23.6	FP-3/4-27-G-10	3/4-GNSVTA-53	46	B2	16	2.5	25
1	4.25	17.5	FP-1-27-G-10	1-GSVTA-64	47	C1	12.9	14.8	11.5
	4.82	19.8	FP-1-27-G-10	1-GSVTA-65	48	C1	15	16.9	14.8
	5.63	23.2	FP-1-27-G-10	1-GNSVTA-64	49	C1	20.7	2.2	11.3
	6	24.7	FP-1-35-G-10	1-GSVTA-64	47	C2	24.6	14.8	6.8
	6.75	27.9	FP-1-35-G-10	1-GSVTA-65	48	C2	27	16.9	8.9
	7.84	32.4	FP-1-35-G-10	1-GNSVTA-64	49	C2	37.7	2.2	6.8
	8.46	35.1	FP-1-35-G-10	1-GSVTA-63	50	C2	45	20.8	13.9
	9	36.9	FP-1-35-G-10	1-GNSVTA-65	52	C2	62.8	2.5	8.9
	9.9	40.6	FP-1-35-G-10	1-GSVTA-66	51	C2	75	8.5	13.4
	10.8	44.5	FP-1-35-G-10	1-GNSVTA-66	53	C2	112	1.5	14.5
	11.1	45.7	FP-1-35-G-10	1-GNSVTA-63	54	C2	120	2.9	13.1

Table 3: Alarm capable design

10A4500 / 10A4600

VA Master™ Indicating Flowrator®

Tube size (in.)	Maximum flow		Tube number	Float number (316 stainless steel)	Float code	Tube code	Total DP (Note 1)	VIC (Note 2)	psia critical (Note 3)
	Water equivalent (gpm) – Q _w	Air equivalent (SCFM) – Q _A							
1½-	13.4	55	FP-1½-27-G-10	1½-GSVTA-84	55	D2	10	27.6	15.4
	15.4	63.5	FP-1½-27-G-10	1½-GSVTA-85	56	D2	14	32	20.3
	16	66	FP-1½-27-G-10	1½-GSVTA-83	57	D2	16	33	22
	17.6	72	FP-1½-27-G-10	1½-GNSVTA-84	58	D2	15	4.2	15.4
	20.4	84	FP-1½-27-G-10	1½-GNSVTA-85	59	D2	18	5	20.3
	21.2	87	FP-1½-27-G-10	1½-GNSVTA-83	60	D2	20	4.9	22
2	23.9	99	FP-2-27-G-10	2-GSVTA-94	61	E1	24	40.5	16.4
	27.9	115.2	FP-2-27-G-10	2-GSVTA-93	62	E1	30	49	24
	31.5	129.8	FP-2-27-G-10	2-GNSVTA-94	63	E1	32	6.1	17.4
	36.9	152.1	FP-2-27-G-10	2-GNSVTA-96	64	E1	47	7.6	21.2
	38.2	156.6	FP-2-27-G-10	2-GNSVTA-93	65	E1	50	7.3	24

Table 3: Alarm capable design (continued)

Notes

1. Pressure drop is total pressure loss across the meter at 100 % flow rate in inches of water column.
2. Meter is unaffected by viscosity when the value of cps/\sqrt{p} (using p = operating density in g/cc and cps = viscosity in centipoise) is less than VIC (viscosity immunity ceiling). VIC is applicable to liquids only – all gas flows fall below VIC.
3. Meters are not recommended for gas service where pressure is below minimum shown. A flow throttling valve close-coupled to meter outlet is not recommended for all gas applications.
4. Unless other is shown, range is equal to, or greater than, 12.5:1.
5. Values for Q_w and Q_A (water and air flow equivalents) can be determined using equations 1-4. See 'Meter sizing' on page 7.

Tube size (in.)	Maximum flow		Tube number	Float number	Float material	Float code	Tube code	Total DP (Note 1)	VIC (Note 2)
	Water equivalent (gpm) – Q _w	Air equivalent (SCFM) – Q _A							
½	0.8		FP-½-17-G-10	BS-41	Tantalum	66	A1	6.2	8
	1		FP-½-21-G-10	BS-41	Tantalum	66	A2	6.7	8
	1.3		FP-½-27-G-10	BS-41	Tantalum	66	A3	7.7	8
	1.9		FP-½-35-G-10	BS-41	Tantalum	66	A4	12	6
	3.32		FP-½-50-G-9	BS-41	Tantalum	66	A6	30	5
¾	1.9		FP-¾-21-G-10	BS-50	Tantalum	67	B1	4.5	10
	2.5		FP-¾-27-G-10	BS-50	Tantalum	67	B2	5.7	10
1	4.4		FP-1-27-G-10	BS-62	Tantalum	68	C1	14.7	16
	5.8		FP-1-27-G-10	BS-60	Tantalum	69	C1	26.5	20
	6.3		FP-1-35-G-10	BS-62	Tantalum	68	C2	18.7	16
	8.1		FP-1-35-G-10	BS-60	Tantalum	69	C2	30	20
1½	8.3		FP-1½-21-G-10	BS-80	Tantalum	70	D1	8.7	24
	11		FP-1½-27-G-10	BS-80	Tantalum	70	D2	11.5	24
2	14.4		FP-2-27-G-10	BS-90	Tantalum	71	E1	10	26
	20.7		FP-2-27-G-10	BS-91	Tantalum	72	E1	19	37

Table 4: Special material floats – tantalum

Notes

1. Pressure drop is total pressure loss across the meter at 100 % flow rate in inches of water column.
2. Meter is unaffected by viscosity when the value of cps/\sqrt{p} (using p = operating density in g/cc and cps = viscosity in centipoise) is less than VIC (viscosity immunity ceiling). VIC is applicable to liquids only – all gas flows fall below VIC.

Tube size (in.)	Maximum flow	Tube number	Float number	Float material	Float code	Tube code	Total DP (Note 1)	VIC (Note 2)
	Water equivalent (gpm) – Q _w							
1/2	0.55	FP-1/2-17-G-10	1/2-GL-471	PTFE	73	A1	3.5	1.8
	0.66	FP-1/2-21-G-10	1/2-GL-471	PTFE	73	A2	3.68	1.8
	0.96	FP-1/2-27-G-10	1/2-GL-471	PTFE	73	A3	4.6	1.8
	1.02	FP-1/2-17-G-10	1/2-GL-410	PVC	74	A1	9	2.45
	1.33	FP-1/2-21-G-10	1/2-GL-410	PVC	74	A2	10.1	2.45
	1.42	FP-1/2-35-G-10	1/2-GL-471	PTFE	73	A4	9	1.8
	1.92	FP-1/2-27-G-10	1/2-GL-410	PVC	74	A3	12.7	2.45
	2.13	FP-1/2-50-G-9	1/2-GL-471	PTFE	73	A6	12	1.8
	2.85	FP-1/2-35-G-10	1/2-GL-410	PVC	74	A4	18.7	2.45
3/4	4.9	FP-1/2-50-G-9	1/2-GL-410	PVC	74	A6	40	2.45
	1.95	FP-3/4-21-G-10	3/4-GL-571	PTFE	75	B1	5.13	2.2
	4.2	FP-3/4-21-G-10	3/4-GL-510	PVC	76	B1	14.6	2.97
1	5.87	FP-3/4-27-G-10	3/4-GL-510	PVC	76	B2	19.1	2.97
	4.55	FP-1-27-G-10	1-GL-671	PTFE	77	C1	15.6	3
	9.72	FP-1-27-G-10	1-GL-610	PVC	78	C1	54.3	3.89
1 1/2	14.7	FP-1-35-G-10	1-GL-610	PVC	78	C2	70	3.89
	9.38	FP-1 1/2-21-G-10	1 1/2-GL-871	PTFE	79	D1	11.4	3.98
	13.3	FP-1 1/2-27-G-10	1 1/2-GL-871	PTFE	79	D2	15.9	3.98
	23.5	FP-1 1/2-21-G-10	1 1/2-GL-810	PVC	80	D1	44	6.4
2	32.6	FP-1 1/2-27-G-10	1 1/2-GL-810	PVC	80	D2	73	6.4
	21.8	FP-2-27-G10	2-GL-971	PTFE	81	E1	22.2	5.95
	56.7	FP-2-27-G10	2-GL-910	PVC	82	E1	105	9.7

Table 5: Special material floats – PVC and PTFE

Notes

1. Pressure drop is total pressure loss across the meter at 100 % flow rate in inches of water column.
2. Meter is unaffected by viscosity when the value of $\text{cps}/\sqrt{\rho}$ (using ρ = operating density in g/cc and cps = viscosity in centipoise) is less than VIC (viscosity immunity ceiling). VIC is applicable to liquids only – all gas flows fall below VIC.

10A4500 / 10A4600

VA Master™ Indicating Flowrator®

Dimensions

In-Line mounting – horizontal connections (stainless steel fittings)

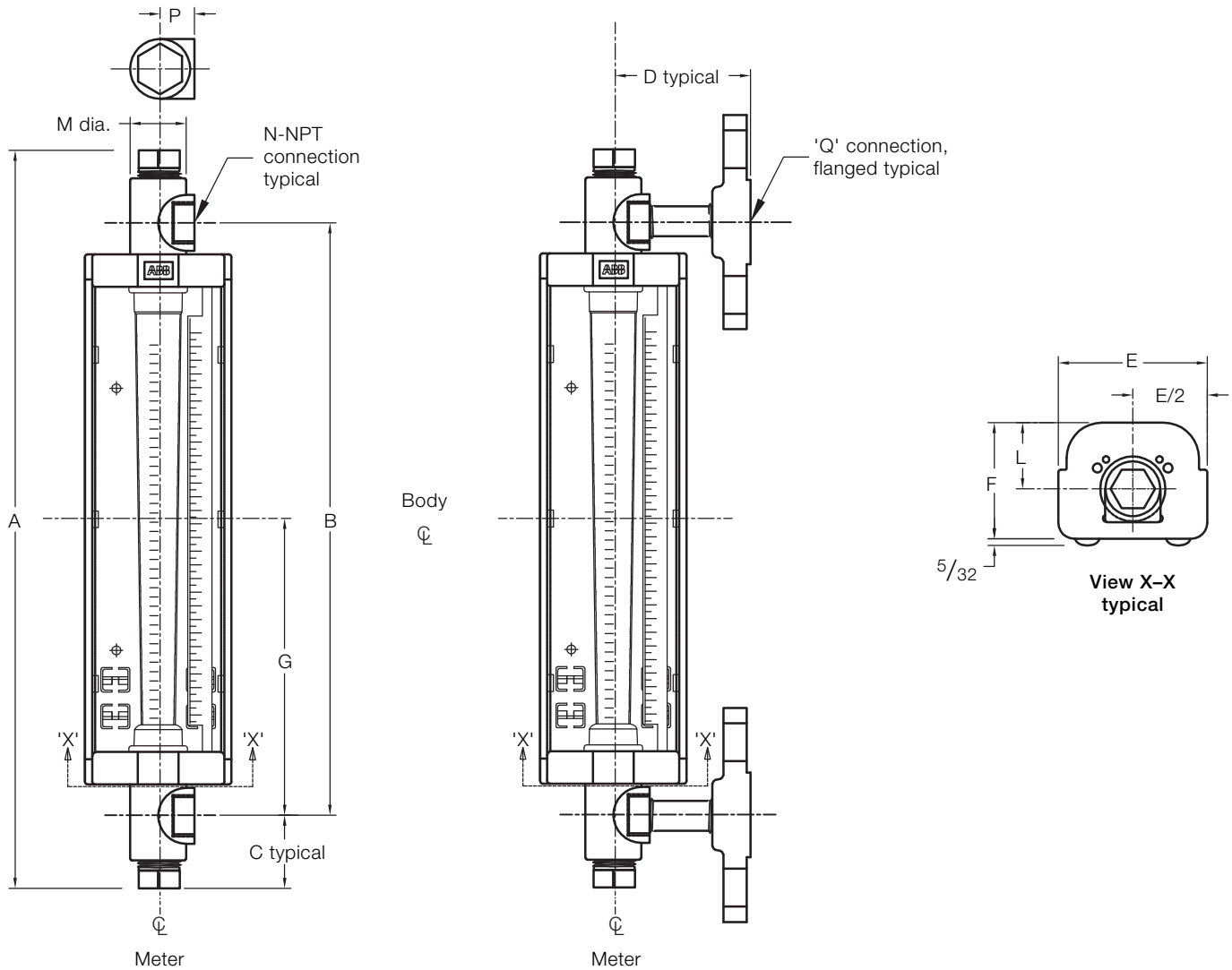

Meter tube	1/2 in.		3/4 and 1 in.		1 1/2 to 2 in.	
Dim.	in.	mm	in.	mm	in.	mm
A	19 ⁵ / ₁₆	490	21 ³ / ₁₆	538	26 ⁷ / ₁₅	671
B	16 ¹ / ₂	419	17 ¹ / ₂	445	20 ¹ / ₂	521
C	1 ¹³ / ₃₂	37	1 ²⁷ / ₃₂	47	2 ³¹ / ₃₂	75
D	3 ¹ / ₂	89	4	103	5	127
E	3 ³ / ₈	86	4 ³ / ₈	111	5 ¹¹ / ₁₆	144
F	2 ⁵ / ₈	67	3 ²⁷ / ₆₄	87	4 ⁷ / ₈	124

Meter tube	1/2 in.		3/4 and 1 in.		1 1/2 to 2 in.	
Dim.	in.	mm	in.	mm	in.	mm
G	8 ¹ / ₄	210	8 ³ / ₄	222	10 ¹ / ₄	260
L	1 ¹ / ₂	38	1 ⁵⁹ / ₆₄	49	2 ⁵ / ₈	67
M	1 ¹ / ₄	32	1 ¹ / ₂	38	2 ¹ / ₂	64
N	1/2	13	3/4	19	1 ¹ / ₂	38
P	3/4	19	1 ¹ / ₈	29	1 ⁷ / ₈	48
Q	1/2	13	1	25	1 ¹ / ₂	38

In-Line mounting – vertical connections

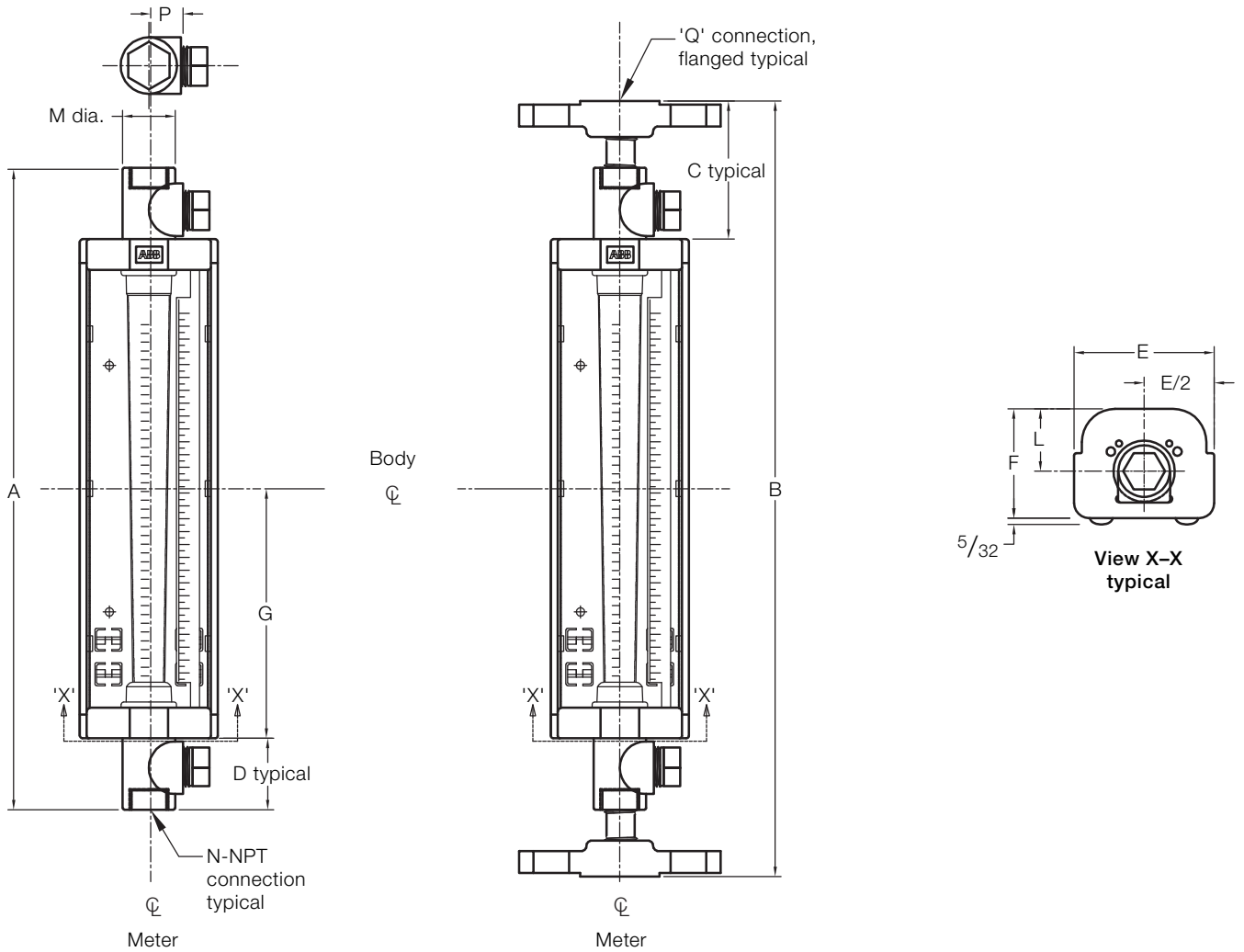

Stainless steel fittings

Meter tube Dim.	1/2 in.		3/4 and 1 in.		1 1/2 to 2 in.	
	in.	mm	in.	mm	in.	mm
A	18 ⁹ / ₁₆	471	20	508	24 ⁵ / ₁₅	618
B	20 ⁵ / ₈	524	22 ¹ / ₈	562	27 ¹¹ / ₁₆	703
C	2 ²¹ / ₃₂	68	3 ⁵ / ₃₂	80	5 ⁷ / ₃₂	133
D	1 ⁵ / ₈	41	2 ³ / ₃₂	53	3 ¹⁷ / ₃₂	90
E	3 ³ / ₈	86	4 ³ / ₈	111	5 ¹¹ / ₁₆	144
F	2 ⁵ / ₈	67	3 ²⁷ / ₆₄	87	4 ⁷ / ₈	124

Meter tube Dim.	1/2 in.		3/4 and 1 in.		1 1/2 to 2 in.	
	in.	mm	in.	mm	in.	mm
G	7 ²¹ / ₃₂	194	7 ²⁹ / ₃₂	201	8 ⁵ / ₈	219
L	1 1/2	38	1 ⁵⁹ / ₆₄	49	2 ⁵ / ₈	67
M	1 1/4	32	1 1/2	38	2 1/2	64
N	1/2	13	3/4	19	1 1/2	38
P	3/4	19	1 1/8	29	1 7/8	48
Q	1/2	13	1	25	1 1/2	38

10A4500 / 10A4600

VA Master™ Indicating Flowrator®

PVC fittings

Meter tube	1/2 in.		3/4 and 1 in.		1 1/2 to 2 in.	
	in.	mm	in.	mm	in.	mm
A	16 ⁵ / ₈	422	17 ⁷ / ₈	454	20 ¹ / ₈	511
B	20 ³ / ₈	518	21 ³ / ₈	543	24 ¹ / ₂	622
C	2 ¹⁷ / ₃₂	64	2 ²⁵ / ₃₂	71	3 ⁵ / ₈	92
D	5/8	16	1 ⁵ / ₁₆	24	1 ¹ / ₁₆	27
E	3 ³ / ₈	86	1 ⁵ / ₁₆	24	1 ¹ / ₁₆	27
F	2 ⁵ / ₈	67	3 ²⁷ / ₆₄	87	4 ⁷ / ₈	124

Meter tube	1/2 in.		3/4 and 1 in.		1 1/2 to 2 in.	
	in.	mm	in.	mm	in.	mm
G	7 ²¹ / ₃₂	194	7 ²⁹ / ₃₂	201	8 ⁵ / ₈	219
L	1 1/2	38	1 ⁵⁹ / ₆₄	49	2 ⁵ / ₈	67
M	1 1/2	38	2 ¹ / ₄	57	3 ³ / ₄	95
N	1/2	13	3/4	19	1 1/2	38
Q	1/2	13	1	25	1 1/2	38

Panel mounting – rear

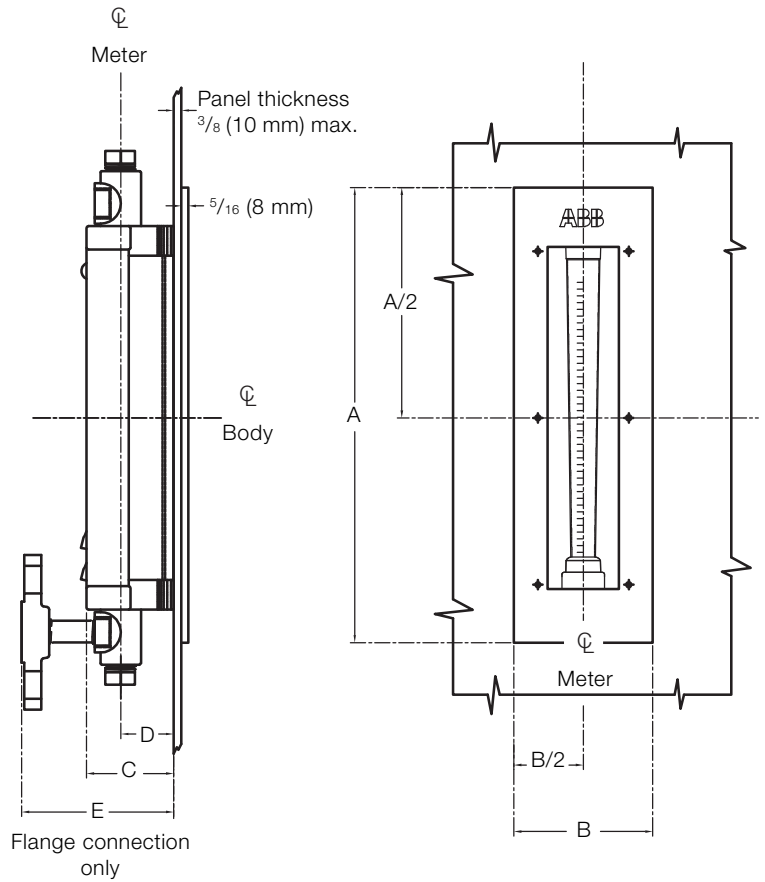
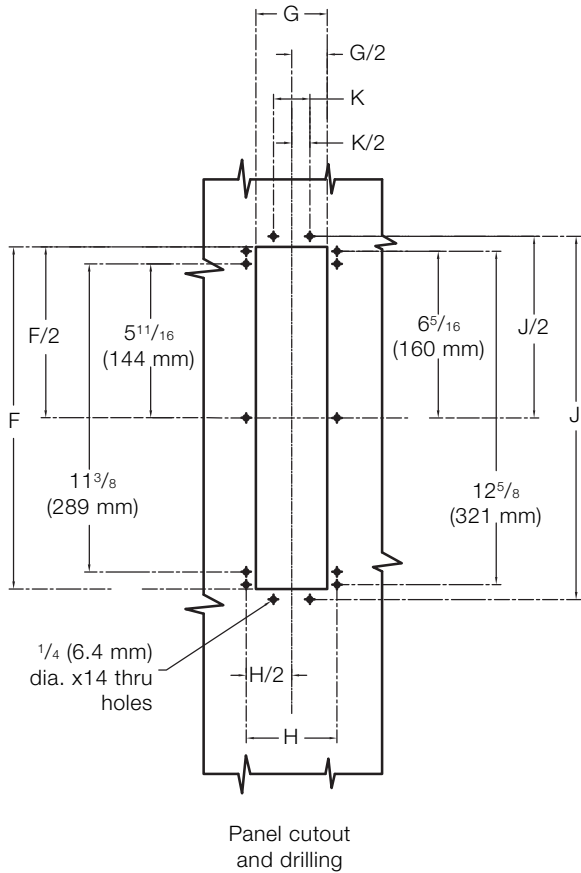

Connection size	1/2 in.		3/4 and 1 in.		1 1/2 in.	
	in.	mm	in.	mm	in.	mm
Scale length	10 in.		10 in.		10 in.	
Dim.	in.	mm	in.	mm	in.	mm
A	16 ³ / ₁₆	411	16 ³ / ₁₆	411	17 ³ / ₄	451
B	4 ⁹ / ₁₆	116	5 ¹ / ₄	133	6 ¹ / ₈	156
C	2 ⁵ / ₈	67	3 ⁷ / ₁₆	87	4 ⁷ / ₈	124
D	1 1/2	38	1 ¹⁵ / ₁₆	49	2 ⁵ / ₈	67
E	5	127	5 ¹⁵ / ₁₆	151	7 ⁵ / ₈	200

Connection size	1/2 in.		3/4 and 1 in.		1 1/2 in.	
	in.	mm	in.	mm	in.	mm
Scale length	10 in.		10 in.		10 in.	
Dim.	in.	mm	in.	mm	in.	mm
F	13 ⁵ / ₈	346	13 ⁷ / ₈	352	15 ⁵ / ₁₆	389
G	2 ¹¹ / ₁₆	68	3 ³ / ₈	86	4 ¹ / ₄	108
H	3 ⁷ / ₁₆	87	4 ¹ / ₈	105	5	127
J	14 ⁷ / ₁₆	367	14 ¹³ / ₁₆	376	16 ¹ / ₄	413
K	1 1/4	32	1 ¹¹ / ₁₆	43	2 ³ / ₈	60

10A4500 / 10A4600

VA Master™ Indicating Flowrator®

Panel mounting – front

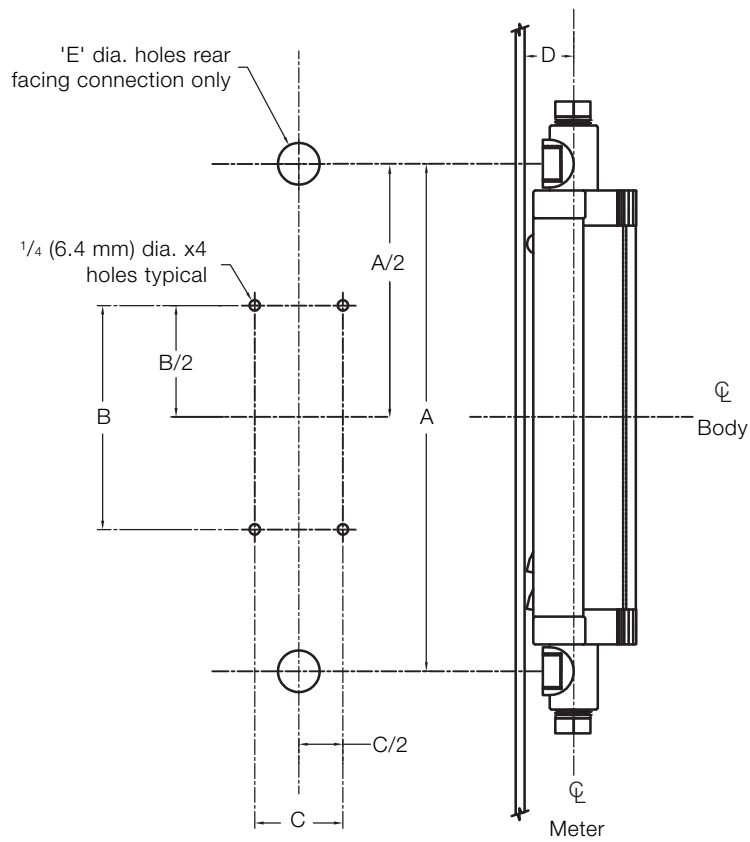

Connection size	1/2 in.		3/4 and 1 in.		1 1/2 in.	
Scale length	10 in.		10 in.		10 in.	
Dim.	in.	mm	in.	mm	in.	mm
A	16 1/2	419	17 1/2	455	20 1/2	521
B	7 9/16	192	7 13/16	198	9 1/4	235
C	2 1/16	52	2 1/2	64	3 1/4	83
D	1 9/32	33	1 21/32	42	2 13/32	61
E (dia)	1 1/8	29	1 3/16	30	2 1/8	54

Ordering information

	Main order code													Additional order code							
	Variant digit number 1 – 4				5,6	7	8	9	10	11	12	13	14	15	16	17	18	19,20	21,22	23	24 to 37
VA Master 10A4500 /	10A4				XX	X	X	X	X	X	X	X	X	X	X	X	X	XX	XX	X	XX
Seals																					
O-Ring					55																
Packing gland					65																
Connection designation																					
Horizontal threaded					5																
Horizontal flanged					6																
Vertical threaded					7																
Vertical flanged					8																
Scale type																					
Percent on tube						X															
Direct reading on tube						Y															
Direct reading metal scale and percent on tube						E															
Percent on metal scale						P															
Direct reading metal scale						S															
Dual direct reading metal scales						D															
Mounting																					
Line mounted							X														
Front panel mounted (see Note 1)							Y														
Rear (flush) panel mounted (see Note 2)							Z														
Design level																					
B																					B
Connection size (see Note 3)																					
Connector – 1/2 in., tube – 1/2 in.																					H
Connector – 3/4 in., NPT, tube – 3/4 in.																					J
Connector – 3/4 in., NPT, tube – 1 in.																					K
Connector – 1 in., flanged, tube – 3/4 in.																					L
Connector – 1 in., flanged, tube – 1 in.																					M
Connector – 1 1/2 in., tube – 1 1/2 in.																					N
Connector – 1 1/2 in. tube – 2 in.																					P
Fitting material																					
AISI 316 stainless steel (1.4401)																					C
PVC (see Note 4)																					F

Continued...

Notes.

1. Not available with flanged connections
2. Not available with vertical flanged connections
3. See capacity tables on pages 8 to 13 for compatible tube size selection
4. Not available with O-ring seals

10A4500 / 10A4600

VA Master™ Indicating Flowrator®

	Main order code													Additional order code					
Variant digit number 1 – 4	5,6	7	8	9	10	11	12	13	14	15	16	17	18	19,20	21,22	23	24 to 37		
VA Master 10A4500 /	10A4	XX	X	X	X	X	X	X	X	X	X	X	X	XX	XX	X	XX		
See page 19																See page 23			
Seal material																			
Packing gland design neoprene (see Note 5)									E										
Packing gland design PTFE									D										
O-Ring design Buna-N (see Note 5)									F										
O-Ring design Viton (not used with ammonia) (see Note 5)									H										
O-Ring design EPDM (see Note 5)									J										
Connection type																			
Threaded (NPT)									B										
Flanged – flat face PVC class 125									C										
Flanged – SST RF class 150									D										
Alarms (see Note 6)																			
Not required										X									
Low alarm, SPDT										C									
High alarm, SPDT										B									
High / low alarm, SPDT										D									
Low alarm, DPDT										F									
High alarm, DPDT										E									
High / low alarm, DPDT										G									
High / high alarm, SPDT										H									
Low / low alarm, SPDT										J									
High / high alarm, DPDT										K									
Low / low alarm, DPDT										L									
Reserved																			
Not required											X								
Inlet connection																			
Front																		1	
Back																		2	
Right																		3	
Left																		4	
Bottom vertical																		5	
Outlet connection																			
Front																		1	
Back																		2	
Right																		3	
Left																		4	
Top vertical																		5	

Continued...

Notes.

- Not available with PVC fittings
- Available only with tube and float combinations specified in capacity Table 3, page 11

				Main order code														Additional order code		
Variant digit number 1 – 4				5,6	7	8	9	10	11	12	13	14	15	16	17	18	19,20	21,22	23	24 to 37
VA Master 10A4500 /				10A4	XX	X	X	X	X	X	X	X	X	X	X	X	XX	XX	X	XX
				See page 19						See page 20								See page 23		
Float (see Note 7)																				
1/2-GUSVT-410	01	2-GSVGT-98A	29								1 1/2-GSVTA-83									
3/4-GUSVT-510	02	2-GNSVGT-97A	30								1 1/2-GNSVTA-84									
1-GUSVT-611	03	2-GNSVGT-98A	31								1 1/2-GNSVTA-85									
1-GUSVT-610	04	BL-954	32								1 1/2-GNSVTA-83									
1 1/2-GUSVT-867	05	BL-953	33								2-GSVTA-94									
1 1/2-GUSVGT-814	06	BL-950	34								2-GSVTA-93									
2-GUSVT-913	07	BL-951	35								2-GNSVTA-94									
2-GUSVT-914	08	1/2-GSVTA-44	36								2-GNSVTA-96									
1/2-GUSVT-40A	09	1/2-GSVTA-48	37								2-GNSVTA-93									
1/2-GSVT-45A	10	1/2-GNSVTA-48	38								BS-41									
1/2-GSVT-44A	11	1/2-GNSVTA-44	39								BS-50									
1/2-GSVT-48A	12	1/2-GNSVTA-43	40								BS-62									
1/2-GNSVT-48A	13	3/4-GSVTA-54	41								BS-60									
3/4-GSVGT-54A	14	3/4-GNSVTA-54	42								BS-80									
3/4-GNSVGT-54A	15	3/4-GSVTA-53	43								BS-90									
3/4-GSVGT-59A	16	3/4-GSVTA-56	44								BS-91									
3/4-GNSVGT-59A	17	3/4-GNSVTA-56	45								1/2-GL-471									
1-GSVGT-64A	18	3/4-GNSVTA-53	46								1/2-GL-410									
1-GSVGT-68A	19	1-GSVTA-64	47								3/4-GL-571									
1-GNSVGT-64A	20	1-GSVTA-65	48								3/4-GL-510									
1-GNSVGT-68A	21	1-GNSVTA-64	49								1-GL-671									
1-GSVGT-69A	22	1-GSVTA-63	50								1-GL-610									
1-GNSVGT-69A	23	1-GSVTA-66	51								1 1/2-GL-871									
1 1/2-GSVGT-87A	24	1-GNSVTA-65	52								1 1/2-GL-810									
1 1/2-GSVGT-86A	25	1-GNSVTA-66	53								2-GL-971									
1 1/2-GNSVGT-87A	26	1-GNSVTA-63	54								2-GL-910									
1 1/2-GNSVGT-86A	27	1 1/2-GSVTA-84	55																	
2-GSVGT-97A	28	1 1/2-GSVTA-85	56																	

Continued...

Notes.

7. Float selection must be compatible with tube selection – refer to capacity tables on pages 8 to 13 and tube ordering information on page 22.

10A4500 / 10A4600

VA Master™ Indicating Flowrator®

Variant digit number 1 – 4	Main order code																		Additional order code
	5,6	7	8	9	10	11	12	13	14	15	16	17	18	19,20	21,22	23	24 to 37		
VA Master 10A4500 /	10A4	XX	X	X	X	X	X	X	X	X	X	X	X	X	XX	XX	X	XX	
See page 19								See page 20						See page 21		See page 23			
Tube (see Note 8)																			
																A1			
FP-1/2-17-G-10																A2			
FP-1/2-21-G-10																A3			
FP-1/2-27-G-10																A4			
FP-1/2-35-G-10																A6			
FP-1/2-50-G-9																B1			
FP-3/4-21-G-10																B2			
FP-3/4-27-G-10																C1			
FP-1-27-G-10																C2			
FP-1-35-G-10																D1			
FP-1 1/2-21-G-10																D2			
FP-1 1/2-27-G-10																E1			
FP-2-27-G-10																			
Float material																			
316 stainless steel (standard)																1			
Hastelloy C																2			
Monel																3			
Tantalum																4			
PVC																5			
PTFE																6			

Notes.

8. Tube selection must be compatible with float selection – refer to capacity tables on pages 8 to 13 and float ordering information on page 21.

Additional ordering information

	Additional order codes						
Variant digit number	24, 25	26, 27	28, 29	30, 31	32, 33	34, 35	36, 37
Calibrations							
Standard; uncalibrated accuracy	C1						
Calibrated accuracy; liquids at 1 ctk. viscosity	C2						
Calibrated accuracy; liquids at viscosity up to 100 ctk. (¹ / ₂ , ³ / ₄ and 1 in.)	C3						
Calibrated accuracy; liquids at viscosity up to 100 ctk. (1 ¹ / ₂ and 2 in.)	C4						
Calibrated accuracy; gas service (stainless steel fittings only)	C6						
External needle valve (stainless steel fittings only)							
¹ / ₂ in. NPT, part number 614C068U03 (see Note 9)		V3					
³ / ₄ in. NPT, part number 614C068U04 (see Note 9)		V4					
Preparation procedure							
Oxygen cleaning per ABB 3BUJ980096			P1				
Certifications							
Certificate of conformance; per order				D1			
Material certifications							
'Typicals' per material					M1		
Pressure test							
Hydrostatic pressure test; ¹ / ₈ to ¹ / ₂ in. diameter							H1
Hydrostatic pressure test; ³ / ₄ to 1 in. diameter							H2
Hydrostatic pressure test; 1 ¹ / ₂ to 2 in. diameter							H3
Tags							
Stainless steel (wired on – per meter)							T1

Notes.

9. Valve sizes must be compatible with process connection size. Contact your local sales representative for other options.

Acknowledgements

Viton is a registered trademark of E. I. du Pont de Nemours and Co.

Hastelloy is a registered trademark of HAYNES International

Monel is a registered trademark of the Special Metals Corporation group of companies

17-7 PH is a registered trademark of AK Steel Corporation

Contact us

ABB Inc.

Process Automation

125 E. County Line Road
Warminster
PA 18974
USA

Tel: +1 215 674 6000

Fax: +1 215 674 7183

www.abb.com

Note

We reserve the right to make technical changes or modify the contents of this document without prior notice. With regard to purchase orders, the agreed particulars shall prevail. ABB does not accept any responsibility whatsoever for potential errors or possible lack of information in this document.

We reserve all rights in this document and in the subject matter and illustrations contained therein. Any reproduction, disclosure to third parties or utilization of its contents in whole or in parts – is forbidden without prior written consent of ABB.

Copyright© 2015 ABB

All rights reserved



Service